

HEX INVERTERS

DESCRIPTION

The 74HC04 types consist of six inverter circuits. They perform the Boolean function $Y = \bar{A}$ in positive logic. Each of the six inverters is a single stage.

APPLICATIONS

- Cameras
- E-Meters
- Infotainment
- Ethernet Switches

ORDERING INFORMATION

Device	Package
74HC04D	SOP-14L



FEATURES

- Wide Operating Voltage Range of 2.0V to 6.0V
- Outputs Can Drive up to 10 LSTTL Loads
- Low Power Consumption, 20 μ A Maximum I_{CC}
- Typical t_{pd} : 8ns
- ± 4 mA Output Drive at 5.0V
- Low Input Current of 1.0 μ A Maximum

ABSOLUTE MAXIMUM RATINGS

(Note 1)

CHARACTERISTIC		SYMBOL	MIN.	MAX.	UNIT
DC Supply Voltage		V_{CC}	-0.5	7	V
Input Clamp Current (Note 2)	$V_I < 0$ or $V_I > V_{CC}$	I_{IK}	-	± 20	mA
Output Clamp Current (Note 2)	$V_O < 0$	I_{OK}	-	± 20	mA
Continuous Output Current	$V_O = 0$ to V_{CC}	I_{IN}	-	± 25	mA
Continuous Current through V_{CC} or GND			-	± 50	mA
Maximum Junction Temperature		T_J	-	150	$^{\circ}$ C
Storage Temperature		T_{STG}	-65	150	$^{\circ}$ C

Note 1. Stresses beyond those listed under Absolute Maximum Ratings may cause permanent damage to the device.

These are stress ratings only and functional operation of the device at these or any other conditions beyond those indicated under Recommended Operating Conditions is not implied. Exposure to absolute-maximum-rated conditions for extended periods may affect device reliability.

Note 2. The input and output negative-voltage ratings may be exceeded if the input and output clamp current ratings are observed.

RECOMMENDED OPERATING CONDITIONS

(Note 3)

CHARACTERISTIC	SYMBOL	MIN.	MAX.	UNIT
Supply Voltage	V_{CC}	2	6	V
DC Input Voltage	V_{IN}	0	V_{CC}	V
DC Output Voltage	V_{OUT}	0	V_{CC}	V
Operating Free-Air Temperature Range	T_A	-40	85	$^{\circ}$ C

Note 3. The device is not guaranteed to function outside its operating ratings.

PIN CONFIGURATION

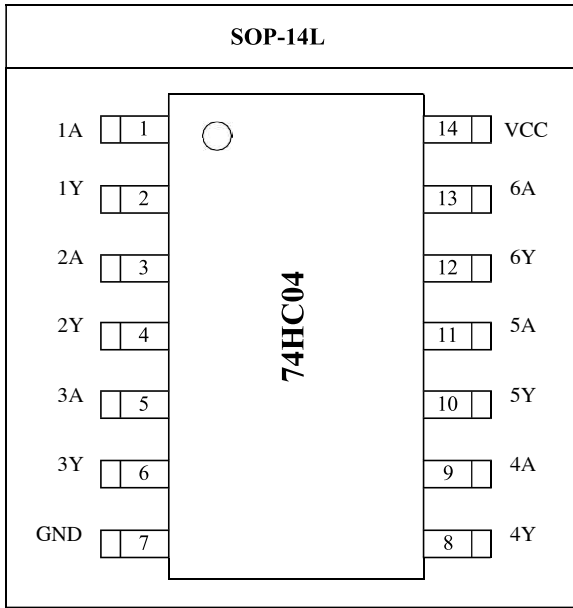

BLOCK DIAGRAM

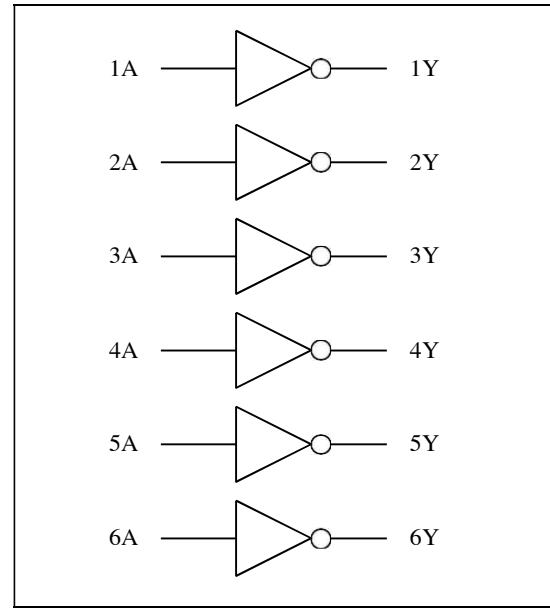

PIN DESCRIPTION

Pin No.	Pin Name	Pin Function
SOP-14L		
1	1A	Input 1
2	1Y	Output 1
3	2A	Input 2
4	2Y	Output 2
5	3A	Input 3
6	3Y	Output 3
7	GND	Ground
8	4Y	Output 4
9	4A	Input 4
10	5Y	Output 5
11	5A	Input 5
12	6Y	Output 6
13	6A	Input 6
14	VCC	Power Supply

ORDERING INFORMATION

Package	Order No.	Description	Supplied As	Status
SOP-14L	74HC04S14	Hex Inverters	Tape & Reel	Active

Note:

- 74HC04S14 devices are Pb-free and RoHS compliant.
- The surface prints of our semiconductor devices are subject to change during the production process and do not involve changes in electrical parameters, and we will not separately state the notice.
- If you have any other custom purchase needs, please contact our sales department.



ESD SENSITIVITY CAUTION

ESD damage can range from subtle performance degradation to complete device failure. Precision integrated circuits may be more susceptible to damage because very small parametric changes could cause the device not to meet its published specifications.



Product Folder



Order Now



Technical Documents



Tools & Software



Support & Community

Note:

- The information described herein is subject to change without notice.
- ForDevices Inc. is not responsible for any problems caused by circuits or diagrams described herein whose related industrial properties, patents, or other rights belong to third parties. The application circuit examples explain typical applications of the products, and do not guarantee the success of any specific mass-production design.
- Use of the information described herein for other purposes and/or reproduction or copying without the express permission of ForDevices Inc. is strictly prohibited.
- The products described herein cannot be used as part of any device or equipment affecting the human body, such as exercise equipment, medical equipment, security systems, gas equipment, or any apparatus installed in airplanes and other vehicles, without prior written permission of ForDevices Inc.
- Although ForDevices Inc. exerts the greatest possible effort to ensure high quality and reliability, the failure or malfunction of semiconductor products may occur. The user of these products should therefore give thorough consideration to safety design, including redundancy, fire-prevention measures, and malfunction prevention, to prevent any accidents, fires, or community damage that may ensue.

▲ Update by Apr.2018