

Mono 1W Filterless Non Clip class D Audio Power Amplifier

■ Description

FH2011N is a 1.0W(RL=8) Class-D audio power amplifier. FH2011N uses the filter-less method allowing the speaker to be directly connected to the output and features low-level distortion and noise characteristics.

FH2011N has non-clip function to control gain automatically and prevent output signal from being clipped at the supply voltage.

FH2011N has over-current and over-temperature protection function, under-voltage locked function, as well as EMI noise and pop noise reduction functions.

The FH2011N is available in SOT-23-6L packages.

■ Application Information

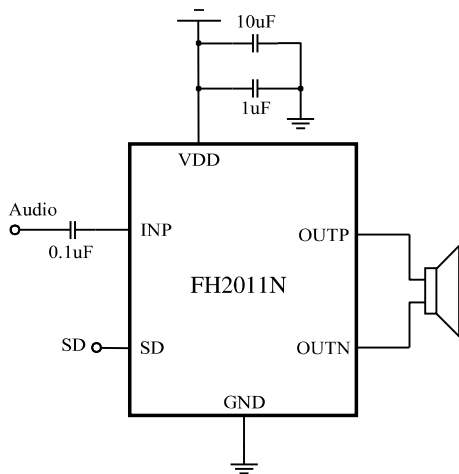

■ Features

- 1.0W Output at 1% THD with 8 load at 5V Power Supply
- Filterless, Low Quiescent Current and Low EMI
- High Efficiency up to 89%
- Soft Start Function
- VULO and OCP Protection
- Thermal Shutdown
- Pb-Free Package

■ Package Type

- SOT-23-6L

■ Application

- Wireless or Cellular Handsets and PDAs
- Personal Navigation devices
- General Portable Audio devices

■ Pin Configuration

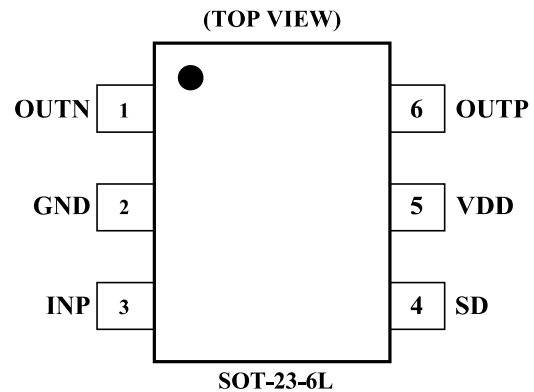

■ Pin Description

Pin Number	Pin Name	Function Description
SOT-23-6L		
4	SD	Chip Enable
-	NC	Not connected
3	INP	Positive Input
-	INN	Negative Input
6	OUTP	Positive Output
5	VDD	Power Supply
2	GND	Ground
1	OUTN	Negative Output

1W 超低EMI 防破音 无需滤波 D 类音频功率放大器

■ 产品概述

FH2011N 是一款1W (RL=8) 的 D 类音频功率放大器。FH2011N 没有滤波器, 使得扬声器可以直接连到输出, 并且具有低失真、低噪声的特点。FH2011N 利用无破音技术控制自动增益, 防止输出信号因为输入信号出现失真。FH2011N 具有过流保护、过温保护、欠压锁定等功能, 以及降低 EMI 跟“砰砰”噪声功能。

FH2011N 使用 SOT-23-6L 小封装形式。

■ 产品应用

- 移动电话
- MP3 播放器
- PDA
- 个人导航设备
- 便携式音频设备

■ 典型应用电路

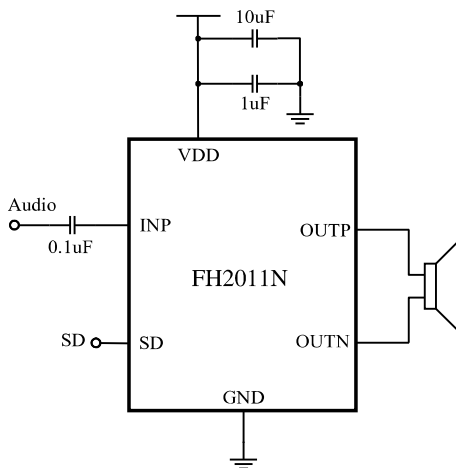

■ 产品特点

- 1W 输出 (THD=1%, RL=8, Power Supply=5V)
- 无滤波器、低静态电流、低 EMI
- 高效率 $\eta = 89\%$
- 软启动功能
- 过流保护
- 欠压锁定
- 过温保护
- 小封装

■ 封装形式

- SOT-23-6L

■ Package Information

- Type: SOT-23-6L

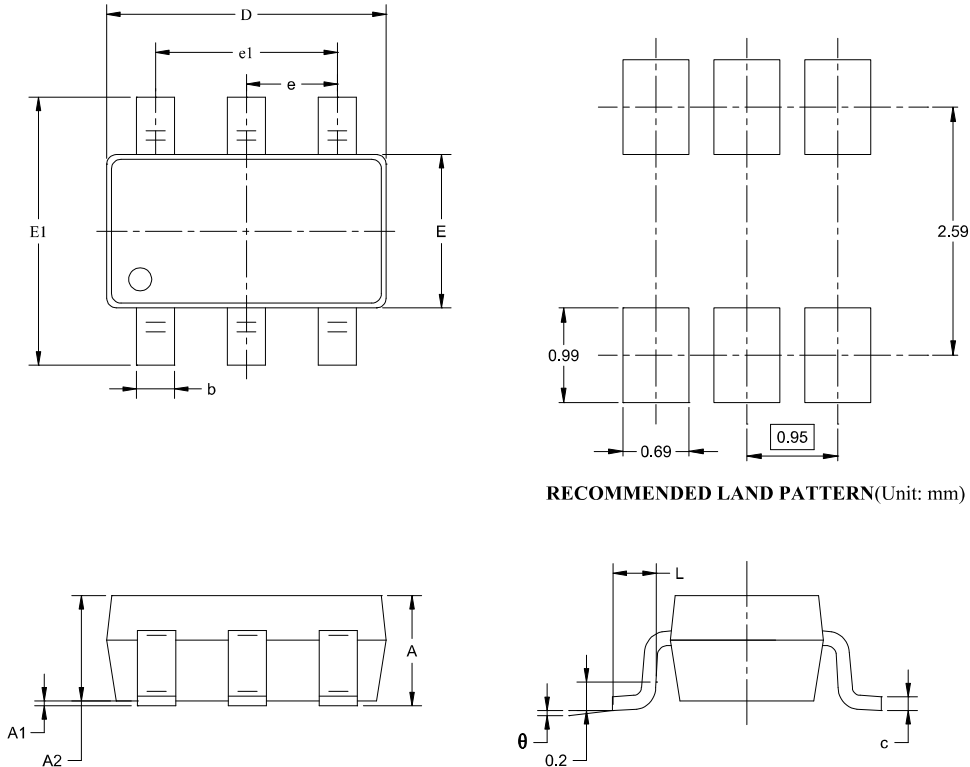

Symbol	Dimensions In Millimeters		Dimensions In Inches	
	MIN	MAX	MIN	MAX
A	1.050	1.250	0.041	0.049
A1	0.000	0.100	0.000	0.004
A2	1.050	1.150	0.041	0.045
b	0.300	0.500	0.012	0.020
c	0.100	0.200	0.004	0.008
D	2.820	3.020	0.111	0.119
E	1.500	1.700	0.059	0.067
E1	2.650	2.950	0.104	0.116
e	0.950 BSC		0.037 BSC	
e1	1.900 BSC		0.075 BSC	
L	0.300	0.600	0.012	0.024
θ	0°	8°	0°	8°

Ordering Information

Part Number	Voltage Range	Features	Operating Temperature	Package Type	Top Mark	SPQ
FH2011NM6	2.5V ~ 5.5V	<ul style="list-style-type: none"> • Single Audio Input • Output Power:1.0W • Efficiency up to 89% • Type: Class-D 	-40°C to 85°C	SOT-23-6L	D1A <u>X</u>	3000PCS/Reel

Note:

- **FH2011N** devices are Pb-free and RoHs compliant.
- The surface prints of our semiconductor devices are subject to change during the production process and do not involve changes in electrical parameters, and we will not separately state the notice.
- If you have any other custom purchase needs, please contact our sales department.



ESD SENSITIVITY CAUTION

ESD damage can range from subtle performance degradation to complete device failure. Precision integrated circuits may be more susceptible to damage because very small parametric changes could cause the device not to meet its published specifications.



Product Folder



Order Now



Technical Documents



Tools & Software



Support & Community

Note:

- The information described herein is subject to change without notice.
- ForDevices Inc. is not responsible for any problems caused by circuits or diagrams described herein whose related industrial properties, patents, or other rights belong to third parties. The application circuit examples explain typical applications of the products, and do not guarantee the success of any specific mass-production design.
- Use of the information described herein for other purposes and/or reproduction or copying without the express permission of ForDevices Inc. is strictly prohibited.
- The products described herein cannot be used as part of any device or equipment affecting the human body, such as exercise equipment, medical equipment, security systems, gas equipment, or any apparatus installed in airplanes and other vehicles, without prior written permission of ForDevices Inc.
- Although ForDevices Inc. exerts the greatest possible effort to ensure high quality and reliability, the failure or malfunction of semiconductor products may occur. The user of these products should therefore give thorough consideration to safety design, including redundancy, fire-prevention measures, and malfunction prevention, to prevent any accidents, fires, or community damage that may ensue.