

## 2.5A, 3.0MHz Switching Charger with Dynamic Power Path in 8-Lead ESOP

### DESCRIPTION

FH5301 is a switching Li-ion battery charger with dynamic power-path control and input current limiting.

When a battery is connected, depending on the battery voltage, the DC-DC switching regulator either pre-conditions, fast-charges the battery or just regulates a system voltage ( $V_{SYS}$ ) to a preset voltage. It does not require an external sense resistor for current sensing. The fast-charging current is determined by programming ISET pin. When the battery voltage reaches the termination voltage i.e. 4.35V, the charging path disconnects SYS to BATT.

The FH5301 also includes a dynamic power path when the SYS load current exceeds current limit of the DC-DC regulator internally set, the SYS voltage falls below  $V_{BATT}$ , FH5301 turns on the power-path to supplement the system load through the battery.

### FEATURES

- Switching Charger with Power Path Management
- Up to 95% DC-DC Efficiency
- 50mΩ Power Path MOSFET
- Up to 2.5A Max charging current
- Instant on with a dead Battery or no Battery
- No battery detection
- No External Sense resistor
- Programmable Charging Current
- Package type: ESOP-8L

### APPLICATIONS

- Tablet, MID
- Smart Phone
- Power Bank
- GPS
- Portable Media Player
- Portable Hand-held Solution

### TYPICAL APPLICATION

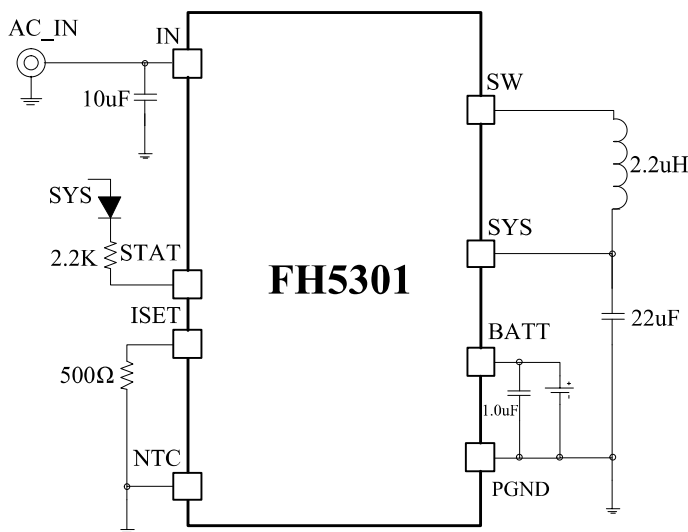
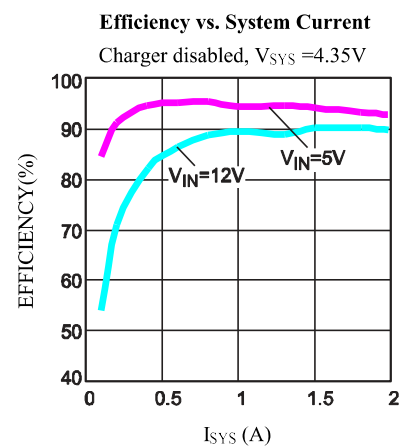
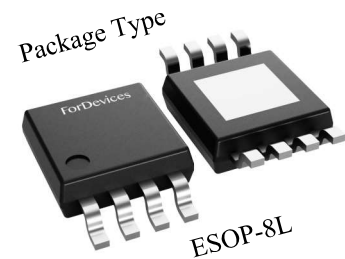
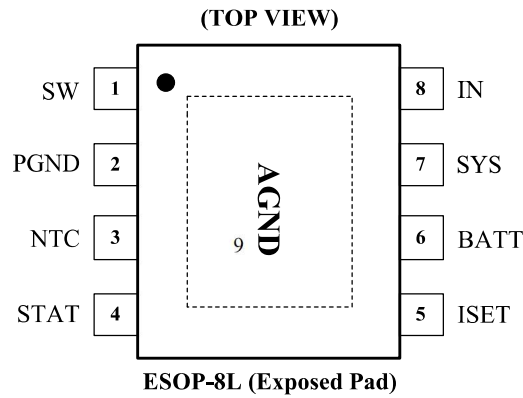

Figure 1. 2.0A Switching Charger with Minimum Component Count



**PIN CONFIGURATION**



**PIN DESCRIPTION**

PIN #	NAME	DESCRIPTION
1	SW	<b>Switching node of the Switching Regulator.</b> Connect a 1.0uH to 2.2uH inductor from this pin to SYS.
2	PGND	<b>Power Ground Pin.</b> Bypass with a 10uF capacitor to IN.
3	NTC	Thermistor input
4	STATS	<b>Status pin for Charging status indications.</b> An open drain device capable of driving 10mA current
5	ISET	<b>Fast Charge Current set pin.</b> Connecting a Resistor between ISET to GND. This sets the fast charge current value.
6	BATT	<b>Battery pin.</b> Connect a Battery to this pin
7	SYS	<b>System Voltage Pin.</b> It is also the Switching regulator's output pin. Connect an inductor and capacitor to form the output filter
8	IN	<b>Input pin.</b> Can be connected to an AC adaptor or a USB charger output. Bypass with a 10uF capacitor each to PGND
9 (EP)	AGND	Exposed pad for analog ground connection. Must be connected to PGND on PCB.

## PACKAGE OUTLINE DIMENSIONS

### ESOP-8L (Exposed Pad)

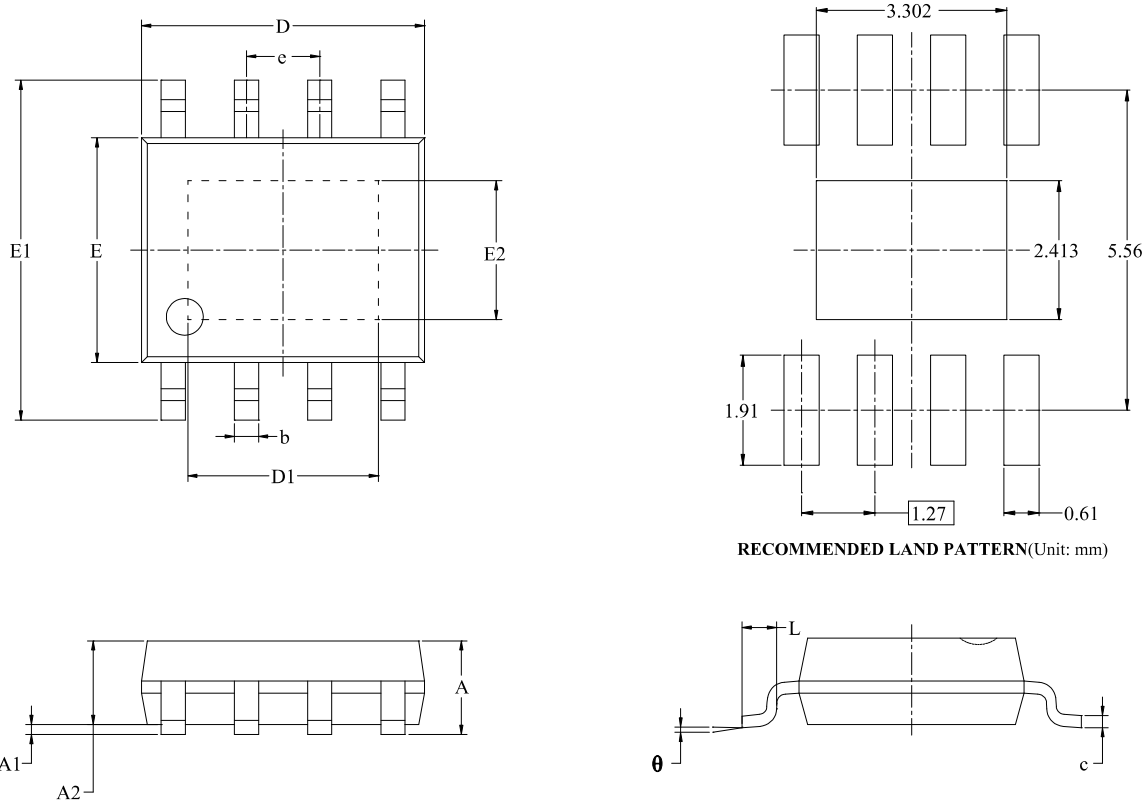

Symbol	Dimensions In Millimeters		Dimensions In Inches	
	MIN	MAX	MIN	MAX
A		1.700		0.067
A1	0.000	0.100	0.000	0.004
A2	1.350	1.550	0.053	0.061
b	0.330	0.510	0.013	0.020
c	0.170	0.250	0.007	0.010
D	4.700	5.100	0.185	0.201
D1	3.202	3.402	0.126	0.134
E	3.800	4.000	0.150	0.157
E1	5.800	6.200	0.228	0.244
E2	2.313	2.513	0.091	0.099
e	1.27 BSC		0.050 BSC	
L	0.400	1.270	0.016	0.050
$\theta$	0°	8°	0°	8°

## ORDERING INFORMATION

Part Number	Voltage Range	Features	Operating Temperature	Package Type	Top Mark	SPQ
FH5301S8	4.4V ~ 5.5V	<ul style="list-style-type: none"> <li>• Battery Charger, buck control</li> <li>• Output current: 2.5A</li> <li>• Efficiency: 95%</li> <li>• Power Path Management</li> <li>• Switch Frequency: 3.0MHz</li> <li>• Battery CV Voltage: 4.35V</li> </ul>	-40°C to 85°C	ESOP-8L	FH5301 YY MM LL	3000PCS/Reel

### Note:

- **FH5301** devices are Pb-free and RoHs compliant.
- The surface prints of our semiconductor devices are subject to change during the production process and do not involve changes in electrical parameters, and we will not separately state the notice.
- If you have any other custom purchase needs, please contact our sales department.
- ForDevices reserves the right to amend and legally interpret the electrical parameters of this chip device. (<http://www.fordevices.com>)

### Device Name: ESOP-8L

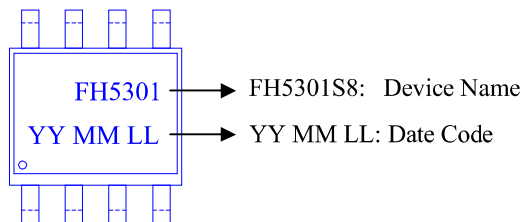

### ESD SENSITIVITY CAUTION

ESD damage can range from subtle performance degradation to complete device failure. Precision integrated circuits may be more susceptible to damage because very small parametric changes could cause the device not to meet its published specifications.



Product Folder



Order Now



Technical Documents



Tools & Software



Support & Community

### Note:

- The information described herein is subject to change without notice.
- ForDevices Inc. is not responsible for any problems caused by circuits or diagrams described herein whose related industrial properties, patents, or other rights belong to third parties. The application circuit examples explain typical applications of the products, and do not guarantee the success of any specific mass-production design.
- Use of the information described herein for other purposes and/or reproduction or copying without the express permission of ForDevices Inc. is strictly prohibited.
- The products described herein cannot be used as part of any device or equipment affecting the human body, such as exercise equipment, medical equipment, security systems, gas equipment, or any apparatus installed in airplanes and other vehicles, without prior written permission of ForDevices Inc.
- Although ForDevices Inc. exerts the greatest possible effort to ensure high quality and reliability, the failure or malfunction of semiconductor products may occur. The user of these products should therefore give thorough consideration to safety design, including redundancy, fire-prevention measures, and malfunction prevention, to prevent any accidents, fires, or community damage that may ensue.



▲ Update by Jul.2020