

## 2.0A 2.0MHz 5.5V Synchronous Buck(Step-Down) Converter

### DESCRIPTION

The FH4510C is a high-efficiency, DC-to-DC step-down switching regulators, capable of delivering up to 2A of output current. The device operates from an input voltage range of 2.6V to 5.5V and provides an output voltage from 0.6V to  $V_{IN}$ . Working at a fixed frequency of 2MHz allows the use of small external components, such as ceramic input and output caps, as well as small inductors, while still providing low output ripples. This low noise output along with its excellent efficiency achieved by the internal synchronous rectifier, making FH4510C an ideal replacement for large power consuming linear regulators. Internal soft-start control circuitry reduces inrush current.

Short-circuit and thermal shutdown protection improves design reliability.

The FH4510C is available in SOT-23-5L package.

### FEATURES

- High efficiency: up to 97%
- Up to 2.0A Max output current
- 2.0MHz switching frequency
- Low dropout 100% duty operation
- Internal compensation and soft-start
- Current mode control
- Reference voltage 0.6V
- Logic control shutdown ( $I_Q < 1.0\mu A$ )
- Thermal shutdown, UVLO
- Available in SOT-23-5L

### APPLICATIONS

- Cellular phones
- Digital cameras
- MP3 and MP4 players
- Set top boxes
- Wireless and DSL modems
- USB supplied devices in notebooks
- Portable devices

### TYPICAL APPLICATION

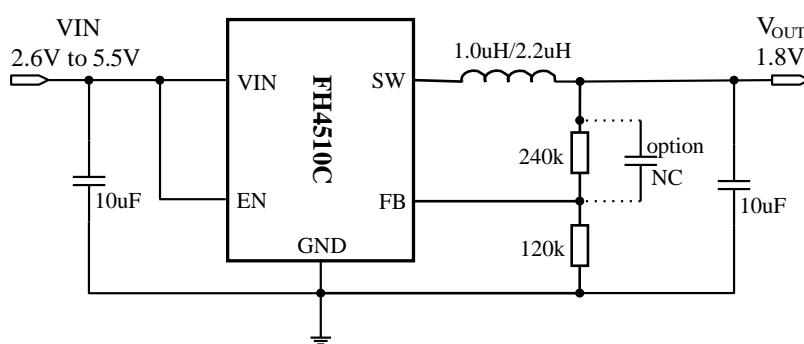
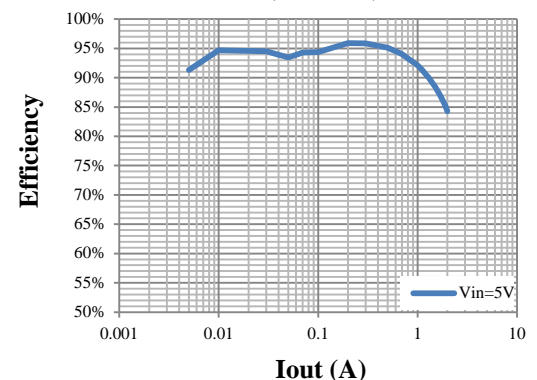
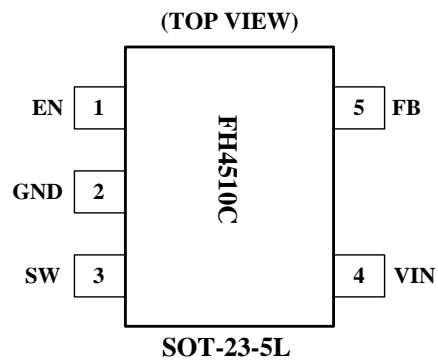

Figure 1. Typical FH4510C Application Circuit

Efficiency vs. Output Current  
( $V_{out}=3.3V$ )



## PIN CONFIGURATION



## PIN DESCRIPTION

PIN #	NAME	DESCRIPTION
1	EN	Enable pin for the IC. Drive the pin to high to enable the part, and low to disable
2	GND	Ground
3	SW	Inductor connection. Connect an inductor between SW and the regulator output.
4	VIN	Supply voltage.
5	FB	Feedback input. Connect an external resistor divider from the output to FB and GND to set the output to a voltage between 0.6V and Vin

## PACKAGE OUTLINE DIMENSIONS

Type: SOT-23-5L

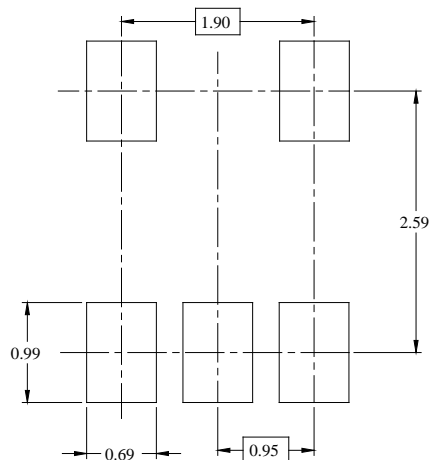
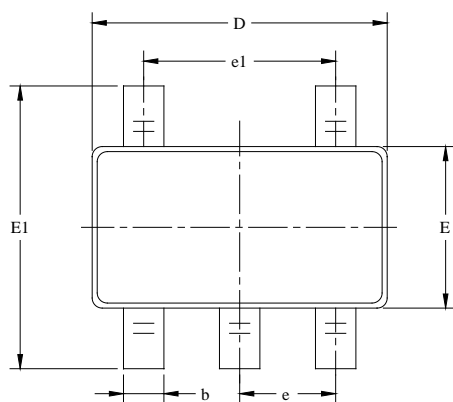

RECOMMENDED LAND PATTERN(Unit: mm)

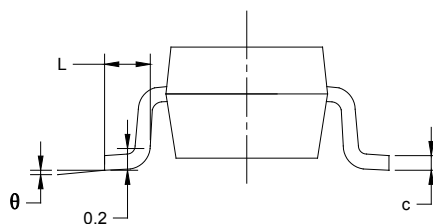
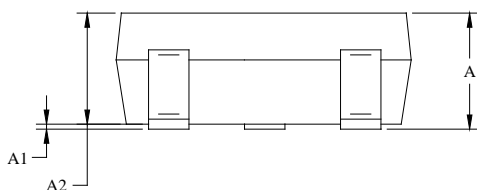

Symbol	Dimensions In Millimeters		Dimensions In Inches	
	MIN	MAX	MIN	MAX
A	1.050	1.250	0.041	0.049
A1	0.000	0.100	0.000	0.004
A2	1.050	1.150	0.041	0.045
b	0.300	0.500	0.012	0.020
c	0.100	0.200	0.004	0.008
D	2.820	3.020	0.111	0.119
E	1.500	1.700	0.059	0.067
E1	2.650	2.950	0.104	0.116
e	0.950 BSC		0.037 BSC	
e1	1.900 BSC		0.075 BSC	
L	0.300	0.600	0.012	0.024
$\theta$	0°	8°	0°	8°

## ORDERING INFORMATION

Part Number	Voltage Range	Features	Operating Temperature	Package Type	Top Mark	SPQ
FH4510CM5	2.6V ~ 5.5V	<ul style="list-style-type: none"> <li>• Synchronous Buck(Step-down)</li> <li>• 97% Efficiency</li> <li>• Switching frequency: 2.0MHz</li> <li>• Iout: Up to 2.0A(Continuous)</li> </ul>	-40°C to 85°C	SOT-23-5L	GU <u>XYZ</u>	3000PCS/Reel

**Note:**

- **FH4510C** devices are Pb-free and RoHs compliant.
- The surface prints of our semiconductor devices are subject to change during the production process and do not involve changes in electrical parameters, and we will not separately state the notice.
- If you have any other custom purchase needs, please contact our sales department.



**Device Name:** SOT-23-5L

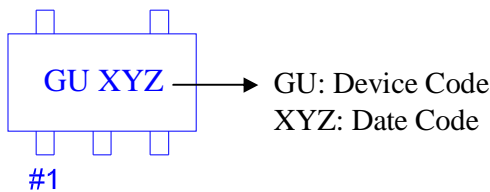

**ESD SENSITIVITY CAUTION**

ESD damage can range from subtle performance degradation to complete device failure. Precision integrated circuits may be more susceptible to damage because very small parametric changes could cause the device not to meet its published specifications.



Product Folder



Order Now



Technical Documents



Tools & Software



Support & Community

**Note:**

- The information described herein is subject to change without notice.
- ForDevices Inc. is not responsible for any problems caused by circuits or diagrams described herein whose related industrial properties, patents, or other rights belong to third parties. The application circuit examples explain typical applications of the products, and do not guarantee the success of any specific mass-production design.
- Use of the information described herein for other purposes and/or reproduction or copying without the express permission of ForDevices Inc. is strictly prohibited.
- The products described herein cannot be used as part of any device or equipment affecting the human body, such as exercise equipment, medical equipment, security systems, gas equipment, or any apparatus installed in airplanes and other vehicles, without prior written permission of ForDevices Inc.
- Although ForDevices Inc. exerts the greatest possible effort to ensure high quality and reliability, the failure or malfunction of semiconductor products may occur. The user of these products should therefore give thorough consideration to safety design, including redundancy, fire-prevention measures, and malfunction prevention, to prevent any accidents, fires, or community damage that may ensue.

▲ Update by Jul.2021