

1.0uA Ultra-Low Quiescent Current, 1.3A Output Synchronous Buck

DESCRIPTION

Datasheet Brief

FEATURES

The FH4509 is a constant frequency, current mode step-down converter. The device integrates a main switch and a synchronous rectifier for high efficiency without an external Schottky diode. It is ideal for powering portable equipment that runs from a single cell Lithium-Ion (Li+) battery. The output voltage can be regulated as low as 1.13V. This device offers two operation modes, PWM control and PFM Mode switching control, which allows a high efficiency over the wider range of the load.

The FH4509 is offered in a low profile 5-pin, SOT package, and is available in an adjustable version.

- Ultra low Iq: 1.0uA
- High Efficiency: Up to 96%
- 1.5MHz Constant Frequency Operation
- Output Current: 1.3A
- No Schottky Diode Required
- Input Voltage Range: 2.6V to 7.0V
- Low Dropout Operation: 100% Duty Cycle
- PFM Mode for High Efficiency in Light Load
- Slope Compensated Current Mode Control for Excellent Line and Load Transient Response
- Short Circuit Protection
- Thermal Fault Protection
- Inrush Current Limit and Soft Start
- Shutdown Current: <1.0uA
- Package type: SOT-23-5L

APPLICATIONS

- IoT Product
- Wearable
- Energy Harvest
- Battery powered devices

TYPICAL APPLICATION

Eff. Vs. Iout

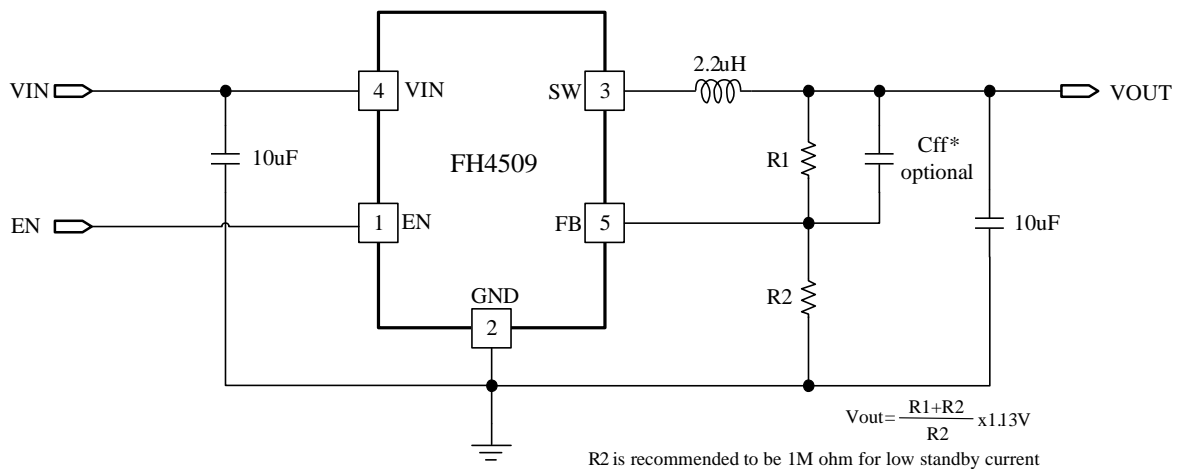
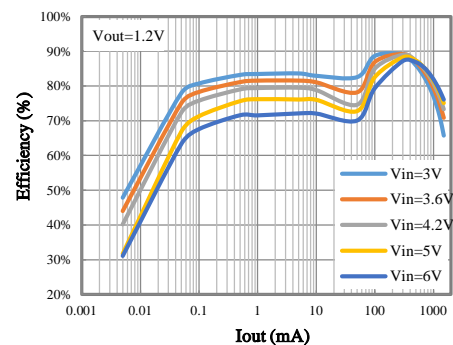
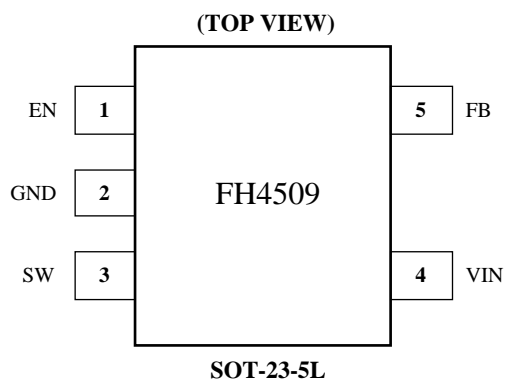

Figure 1. Basic Application Circuit

PIN CONFIGURATIONS



PIN DESCRIPTION

Pin Name	Pin Number	Description
EN	1	Chip Enable Pin. Drive EN above 1.5V to turn on the part. Drive EN below 0.3V to turn it off. Do not leave EN floating.
GND	2	Analog ground pin.
SW	3	Power Switch Output. It is the switch node connection to Inductor. This pin connects to the drains of the internal P-ch and N-ch MOSFET switches.
VIN	4	Power Supply Input. Must be closely decoupled to GND with a 10 μ F or greater ceramic capacitor.
FB	5	Output Voltage Feedback Pin. An internal resistive divider divides the output voltage down for comparison to the internal reference voltage.

PACKAGE DESCRIPTION

SOT-23-5L

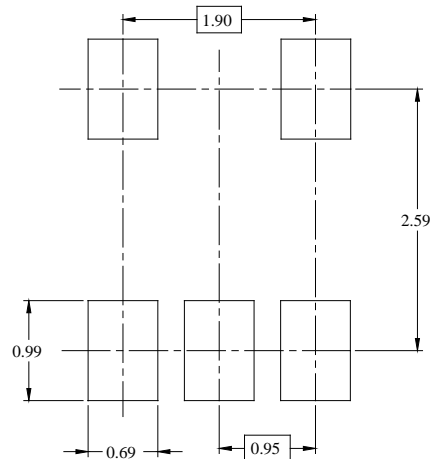
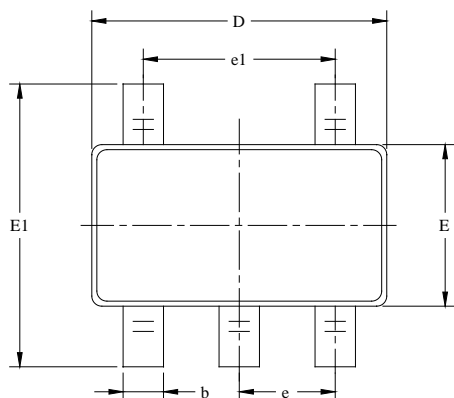

RECOMMENDED LAND PATTERN(Unit: mm)

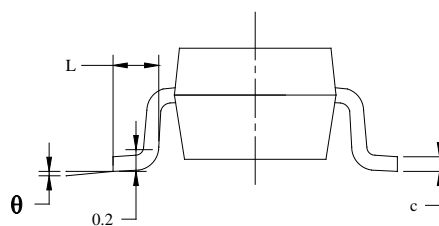
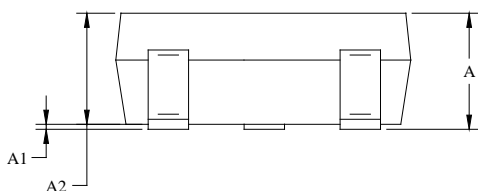

Symbol	Dimensions In Millimeters		Dimensions In Inches	
	MIN	MAX	MIN	MAX
A	1.050	1.250	0.041	0.049
A1	0.000	0.100	0.000	0.004
A2	1.050	1.150	0.041	0.045
b	0.300	0.500	0.012	0.020
c	0.100	0.200	0.004	0.008
D	2.820	3.020	0.111	0.119
E	1.500	1.700	0.059	0.067
E1	2.650	2.950	0.104	0.116
e	0.950 BSC		0.037 BSC	
e1	1.900 BSC		0.075 BSC	
L	0.300	0.600	0.012	0.024
θ	0°	8°	0°	8°

ORDERING INFORMATION

Part Number	Voltage Range	Features	Operating Temperature	Package Type	Top Mark	SPQ
FH4509M5	2.6V ~ 7.0V	<ul style="list-style-type: none"> • DC-DC Buck(Step-down) • Output Current: 1.3A • Frequency: 1.5MHz • Input logic: 3.3V / 5.0V • Iq: 1.0uA(Typ.) • 100% Duty Cycle 	-40°C to 85°C	SOT-23-5L	A01 <u>XYZ</u>	3000PCS/Reel

Note:

- **FH4509** devices are Pb-free and RoHs compliant.
- The surface prints of our semiconductor devices are subject to change during the production process and do not involve changes in electrical parameters, and we will not separately state the notice.
- If you have any other custom purchase needs, please contact our sales department.
- ForDevices reserves the right to amend and legally interpret the electrical parameters of this chip device. (<http://www.fordevices.com>)

Device Name: SOT-23-5L

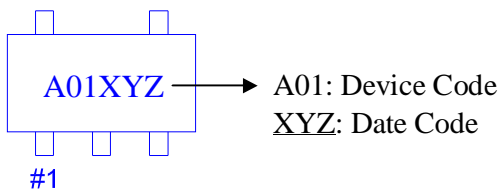

ESD SENSITIVITY CAUTION

ESD damage can range from subtle performance degradation to complete device failure. Precision integrated circuits may be more susceptible to damage because very small parametric changes could cause the device not to meet its published specifications.



Product Folder



Order Now



Technical Documents



Tools & Software



Support & Community

Note:

- The information described herein is subject to change without notice.
- ForDevices Inc. is not responsible for any problems caused by circuits or diagrams described herein whose related industrial properties, patents, or other rights belong to third parties. The application circuit examples explain typical applications of the products, and do not guarantee the success of any specific mass-production design.
- Use of the information described herein for other purposes and/or reproduction or copying without the express permission of ForDevices Inc. is strictly prohibited.
- The products described herein cannot be used as part of any device or equipment affecting the human body, such as exercise equipment, medical equipment, security systems, gas equipment, or any apparatus installed in airplanes and other vehicles, without prior written permission of ForDevices Inc.
- Although ForDevices Inc. exerts the greatest possible effort to ensure high quality and reliability, the failure or malfunction of semiconductor products may occur. The user of these products should therefore give thorough consideration to safety design, including redundancy, fire-prevention measures, and malfunction prevention, to prevent any accidents, fires, or community damage that may ensue.



▲ Update by Dec.2021