

## 单通道触控、单路 PWM 输出，LED 调光控制触摸芯片

PRELIMINARY DATASHEET

## 器件概述

FH8022 是一款单通道电容式触摸输入，单路 PWM 输出，应用于 LED 灯光开关控制及亮度调节的触摸芯片，灯光无闪屏，性能稳定，高抗干扰；可替代机械式轻触按键。

FH8022 可以实现 LED 灯光的触摸开关控制和亮度调节。设计方案所需的外围电路简单，匹配好灵敏度调节电容器，本芯片器件就可以自动克服由于环境温度、湿度、表面杂物等造成的各种干扰，避免由于电阻、电容误差造成的按键差异。

广泛可应用于触摸调光 LED 台灯，触摸调光 LED 壁灯或其他需要 PWM 输出控制的触摸式产品。

FH8022 采用通用的 8 引脚 SOP 贴片封装形式，符合环保规范。

## 典型应用电路

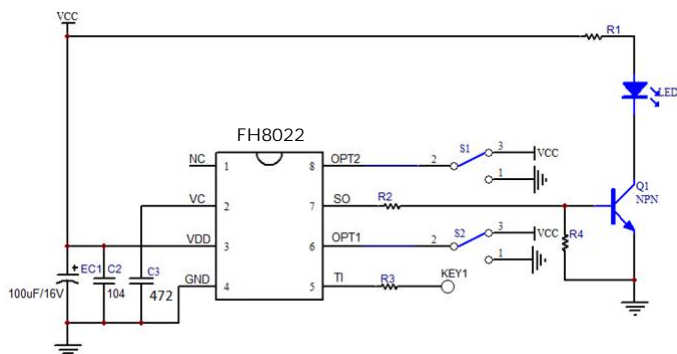

图一、应用电路参考

简要数据手册

## 电气特点

- 工作电压：2.0~5.5V
- 灯光亮度可根据需要随意调节，选择范围广
- PWM 输出频率 31K
- OPT 选项选择四种模式：三种无级调光、三段调光
- 内置软件平滑滤波算法，可有效防止外部噪声干扰而导致的误动作
- 环境值自适应算法，工作环境发生变化可以自动适应
- 应用电路简单，外围器件少，加工方便，成本低
- 抗干扰性能好，ESD 可达 4KV
- 环境工作温度：-20 ~ 70°C
- 可适用于玻璃、陶瓷、塑料、亚克力等介质表面

## 应用领域

- LED 壁灯、台灯、小夜灯
- PWM 输出控制模式的触摸终端

## Device Information (1)

PART NUMBER	PACKAGE	BODY SIZE (NOM)
FH8022	SOP-8L	4.90mm × 3.91mm

(1) For all available packages, see the orderable addendum at the end of the data sheet.

## 引脚分布

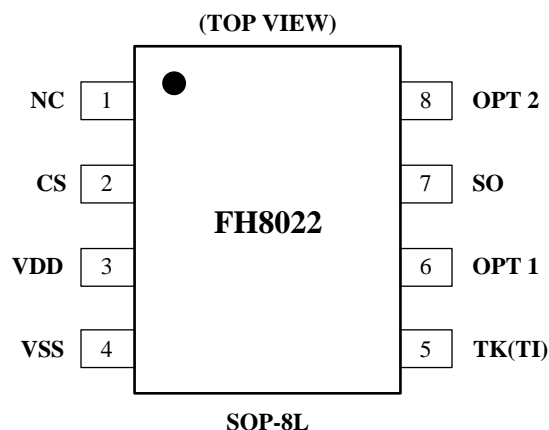

## 引脚功能

引脚序号	引脚名称	输入/输出	功能描述
1	NC	/	悬空, 无连接
2	CS (VC)	输入	采样电容输入脚(建议误差小于 5%的涤纶电容)
3	VDD	电源	电源正端
4	VSS (GND)	电源	接地引脚
5	TK (TI)	输入	触摸按键输入引脚
6	OPT 1	输入	模式选择输入引脚 1
7	SO	输出	灯光控制输出引脚, PWM 输出
8	OPT 2	输入	模式选择输入引脚 2

PACKAGE OUTLINE DIMENSIONS

• Type: SOP-8L

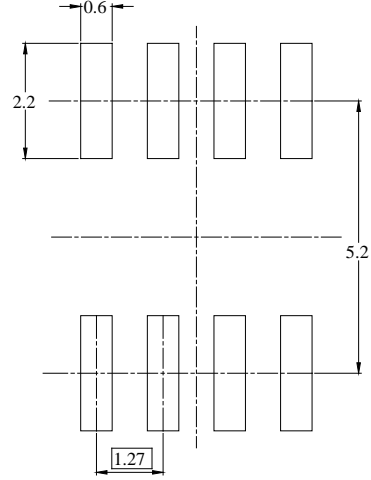
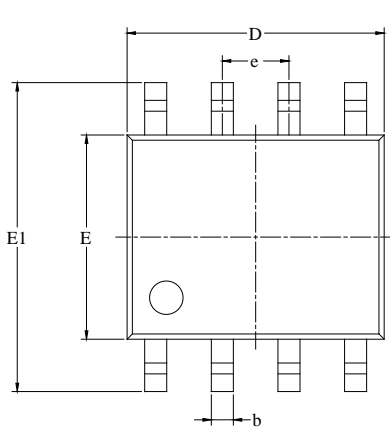

RECOMMENDED LAND PATTERN (Unit: mm)

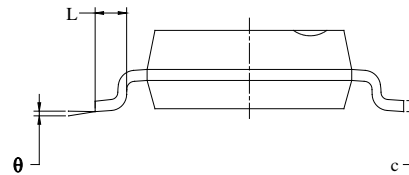
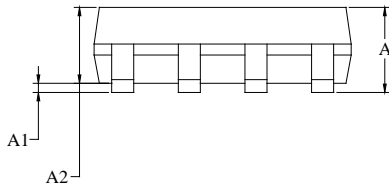

Symbol	Dimensions In Millimeters		Dimensions In Inches	
	MIN	MAX	MIN	MAX
A	1.350	1.750	0.053	0.069
A1	0.100	0.250	0.004	0.010
A2	1.350	1.550	0.053	0.061
b	0.330	0.510	0.013	0.020
c	0.170	0.250	0.006	0.010
D	4.700	5.100	0.185	0.200
E	3.800	4.000	0.150	0.157
E1	5.800	6.200	0.228	0.244
e	1.27 BSC		0.050 BSC	
L	0.400	1.270	0.016	0.050
θ	0°	8°	0°	8°

## ORDERING INFORMATION

Part Number	Input Voltage	Features	Operating Temperature	Package Type	Top Mark	SPQ
FH8022S8	~ 5.5V	<ul style="list-style-type: none"> <li>• Single touch pad key</li> <li>• Single PWM output</li> <li>• Frequency output: 31kHz</li> <li>• OTP #4 Mode</li> </ul>	-20°C to +70°C	SOP-8L	8022 <u>YY WW LL</u>	3000EA/Reel

**Note:**

- **FH8022** devices are Pb-free and RoHs compliant.
- The surface prints of our semiconductor devices are subject to change during the production process and do not involve changes in electrical parameters, and we will not separately state the notice.
- If you have any other custom purchase needs, please contact our sales department.
- FOCMCU Inc. reserves the right to amend and legally interpret the electrical parameters of this chip device. (<http://www.fordevices.com>)

**Device Name: SOP-8L**

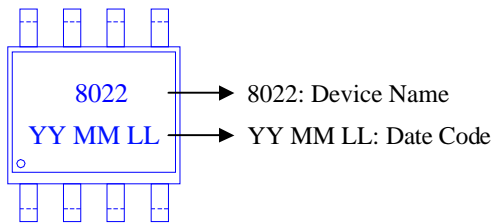

**ESD SENSITIVITY CAUTION**

ESD damage can range from subtle performance degradation to complete device failure. Precision integrated circuits may be more susceptible to damage because very small parametric changes could cause the device not to meet its published specifications.



Product Folder



Order Now



Technical Documents



Tools & Software



Support & Community

**Important Notice:**

- The information described herein is subject to change without notice.
- FOCMCU Inc. is not responsible for any problems caused by circuits or diagrams described herein whose related industrial properties, patents, or other rights belong to third parties. The application circuit examples explain typical applications of the products, and do not guarantee the success of any specific mass-production design.
- Use of the information described herein for other purposes and/or reproduction or copying without the express permission of FOCMCU Inc. is strictly prohibited.
- The products described herein cannot be used as part of any device or equipment affecting the human body, such as exercise equipment, medical equipment, security systems, gas equipment, or any apparatus installed in airplanes and other vehicles, without prior written permission of FOCMCU Inc.
- Although FOCMCU Inc. exerts the greatest possible effort to ensure high quality and reliability, the failure or malfunction of semiconductor products may occur. The user of these products should therefore give thorough consideration to safety design, including redundancy, fire-prevention measures, and malfunction prevention, to prevent any accidents, fires, or community damage that may ensue.

